

SCHEMA TECHNIQUE – UE JET-CO2 QUATTRO STD/DMX

JET DE GAZ
CRYOGENIQUE CO2

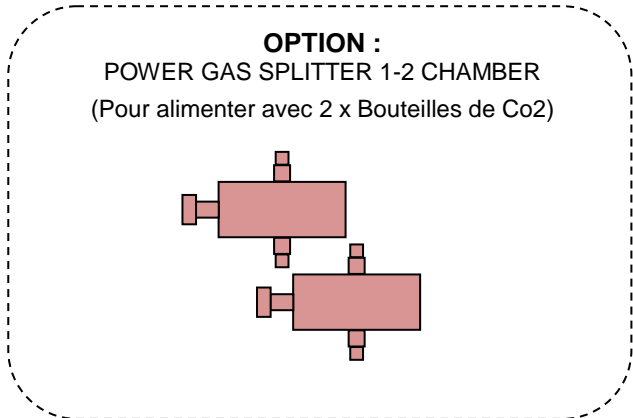
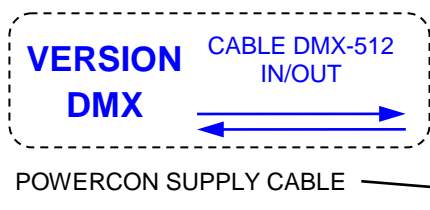
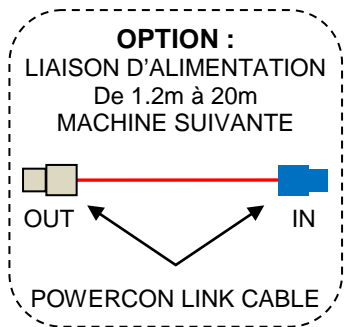
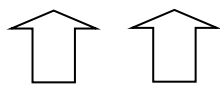

4 x
GAS HP-PIPE

4 x
Bouteilles de CO2
avec tube plongeur
(Bouteille non inclus ;
Demandez notre contrat
de Gaz Partenaire)

OPTION INTERFACE SAFETY PACK

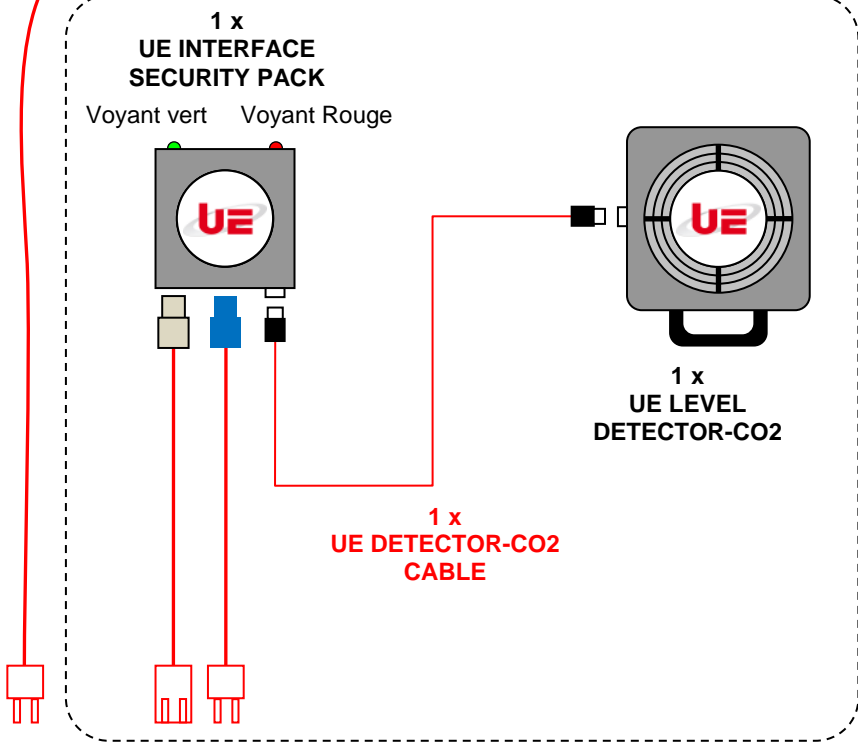

Alimentation
Electrique
220V – 50Hz

4 x
UE
CONNECTION
SYSTEM CO2

OU
4 x
CONNECTION ECO

