



TECHNICAL DATASHEET

UE Head Foam Tube

Item Code : PFPTME007010

The UE Head Foam Tube connects directly to the water network with an automatic mixer by suction system venturi. Designed for ease of use, low noise and very reliable, it is the ideal partner for small events. The machine is delivered with its support, its 5L can, 2 pipes (10 and 15m) and a quick connector for connection to the water network.

NOMENCLATURE:

- 1 x UE Head Foam Tube
- 1 x Tank container support 5 L
- 2 x Connection hoses + quick coupling

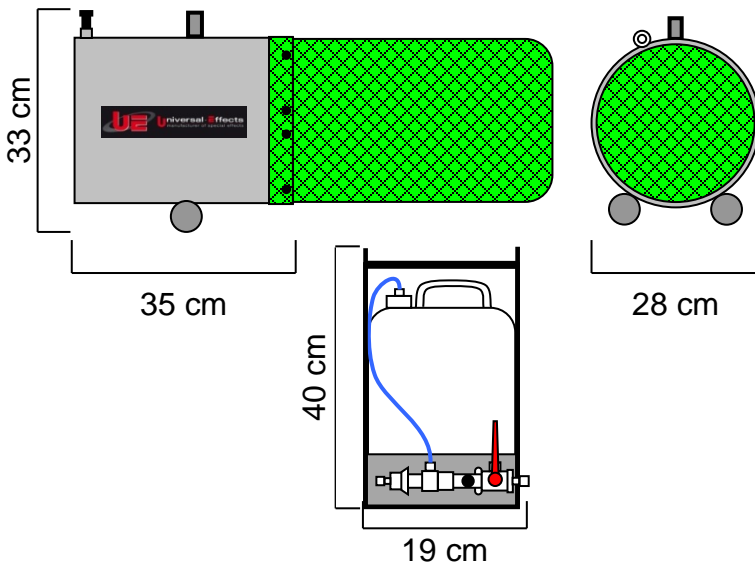

TECHNICAL SPECIFICATIONS :

Size : 35 x 28 x 33 cm
Weight : 8.8 Kg

FEATURES :

Injection of the foam liquid by venturi system.
Production of 30m² / min of foam. Consumption in XT-Power Foam Fluid CC (concentrated foam liquid): 10 L / h.
Direct connection to the water network.
The ideal water pressure required is 3 Bar.
Minimum pressure of 1 bar.
Maximum pressure of 5 bar.

CONSUMABLES :

XT- Foam Fluid LC
XT- Foam Fluid CC
XT- Foam Fluid HC

OPTIONAL ACCESSORIES :

- UE Extended Pipe Tube

Made of ALUMINUM and INOX, the UE Head Foam Tube is built to last. Each element has been chosen for its quality and efficiency.

Universal Effects, La qualité et l'innovation Fabriqué en France

Universal Effects est une Marque fabriquée et distribuée par la société Premium Factory SAS
1 Route Neuve, 71710 MONTCENIS - FRANCE | Email info@premiumfactory.eu | www.premiumfactory.eu
Société Anonyme Simplifiée au capital de 1 000 € | Siret 840 703 797 00018 | VAT Nr: FR47840703797