



TECHNICAL DATASHEET

UE K- Base 350 DMX

Item Code : PFPFBA001111

The UE K-Base 350 DMX is compact, economical and quiet. It is intended for small and medium fixed or mobile installations and visual performances with virtual flames and inflatable Designs. It allows individual or multiple use autonomously, disseminated within the lighting. The variation of the speed is electronically controllable locally and in DMX. The base is equipped with professional connectors and a resettable fuse.

NOMENCLATURE :

- 1 x UE K- Base 350 DMX
- 4 x Boutons de serrages pour les têtes
- 1 x PowerCon cable 5m



TECHNICAL SPECIFICATIONS :

Size : 28 x 62 x 65 cm

Weight : 13 Kg

Electrical Specifications :

230V – 50/60Hz – 355W – 1.55A – IP 44

Conforming to CE standards ERP 2015

FEATURES :

Noise 74 dB / 3m inside (high speed version).

110 ° vertical adjustment.

Possibility of hanging under structure.

Optional floor stand.

Electronic variation of the integrated speed.

Integrates an electronic control with Timer and DMX.

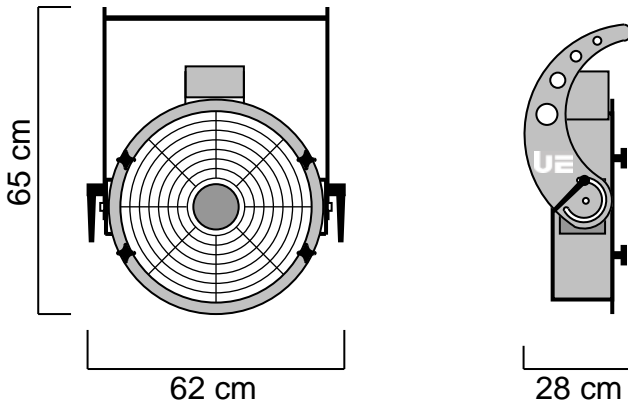

HEADS USABLES :

UE Head Foam 350

UE Head Snow 350

UE Head Twin 350

UE Head Fragances 350

UE Head Jet-Bubbles 350

UE Head Striptease 350

UE Head Wind 350

UE Head AirFlame 350

OPTIONAL ACCESSORIES :

- UE Ground Foot 350

Made of ALUMINUM and INOX, the UE K-Base 350 DMX is built to last. Each element has been chosen for its quality and efficiency.

Universal Effects, La qualité et l'innovation Fabriqué en France

Universal Effects est une Marque fabriquée et distribuée par la société Premium Factory SAS

1 Route Neuve, 71710 MONTCENIS - FRANCE | Email info@premiumfactory.eu | www.premiumfactory.eu

Société Anonyme Simplifiée au capital de 1 000 € | Siret 840 703 797 00018 | VAT Nr: FR47840703797



TECHNICAL DATASHEET

UE Head Fragrance 350 Duo

Item Code : PFPFFR001116

The UE Head Fragrance incorporates a high performance and precise technology in terms of fragrance diffusion. Thanks to its power, the Fragrance head allows you to change perfume in a few seconds and distribute them in all types of volumes. Using 100% natural essential oils, you will create a fourth dimension and use a rarely used meaning: the sense of smell. Available in mono, duo and quattro for more choice and power.

NOMENCLATURE :

- 1 x UE Head Fragrance 350 Duo



TECHNICAL SPECIFICATIONS :

Size : 45 x 42 x 36 cm

Weight : 8.8 Kg

Electrical Specifications :
230V – 50Hz – 22W – 0.1A

Equipped with 2 diffusers of 20ml.

FEATURES :

Equipped with a door for easy access to the diffuser for filling and cleaning.
Designed for horizontal use only.
Integrated electronic control with TIMER and DMX.
Independent control of each scent.

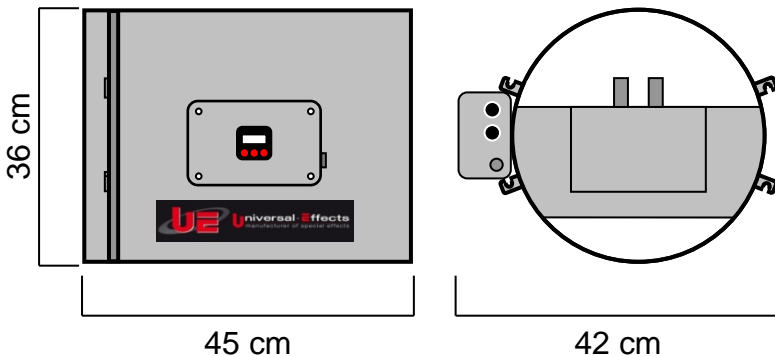

OPTIONAL ACCESSORIES :

- Large capacity diffuser 50 ml

CONSUMPTION :

The consumption varies according to the essential oil used, on average: 1 ml / h per diffuser.

CONSUMABLES :

Perfume compositions specially formulated and adapted by Universal-Effects for its machines.

Made of ALUMINUM and INOX, the UE Head Fragrance 350 Duo is built to last. Each element has been chosen for its quality and efficiency.

Universal Effects, La qualité et l'innovation Fabriqué en France

Universal Effects est une Marque fabriquée et distribuée par la société Premium Factory SAS
1 Route Neuve, 71710 MONTCENIS - FRANCE | Email info@premiumfactory.eu | www.premiumfactory.eu
Société Anonyme Simplifiée au capital de 1 000 € | Siret 840 703 797 00018 | VAT Nr: FR47840703797