



TECHNICAL DATASHEET

UE ST- Base 350 DMX

Item Code : PFPFBA001112

The UE ST-Base 350 is very powerful and equipped with our traditional professional base that allow using on the ground, elevated foot, shoot tower or hang under a structure. It is also suitable for service companies and for fixed installations designed to operate inside and outside. The speed variation is electronically manageable locally or DMX. The base is equipped with professional connectors and a resettable fuse.

NOMENCLATURE :

- 1 x UE ST- Base 350 DMX
- 5 x Tightening buttons for heads
- 1 x PowerCon cable 5m



TECHNICAL SPECIFICATIONS :

Size: 40 x 63 x 57 cm

Weight : 20.2 Kg

Electric Characteristics :
230V – 50/60Hz – 550W – 3.8A – IP 55

Comply with norm CE ERP 2015

CHARACTERISTICS :

Sound 84 dB / 3m inside
Sound 74 dB / 3m outside.
Standard base ground.
Adjustment 110° vertical.
Can be hung under structure.
Electronic speed variation integrated in the base.
Include an electronic control with timer and DMX.

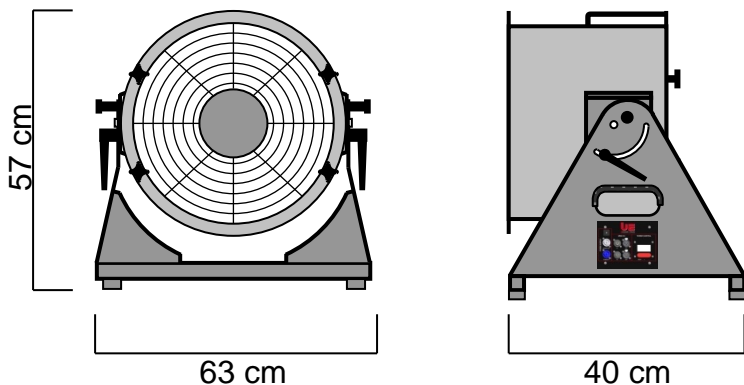

HEADS USABLE :

- | | |
|-----------------------|-------------------------|
| UE Head Foam 350 | UE Head Jet-Foam 350 |
| UE Head Snow 350 | UE Head Mist&Rain 350 |
| UE Head Twin 350 | UE Head Wind 350 |
| UE Head Fragances 350 | UE Head Jet-Bubbles 350 |
| UE Head AirFlame 350 | UE Head Projection 350 |

OPTIONAL ACCESSORIES:

- UE Skate Board 350
- UE Feet 50, 70, 100 (x 4)
- UE Shoot Tower 350

Manufactured in ALUMINIUM and STAINLESS, UE ST- Base 350 DMX is done for last. Each element was chosen for his quality and efficiency.

Universal Effects, La qualité et l'innovation Fabriqué en France

Universal Effects est une Marque fabriquée et distribuée par la société Premium Factory SAS
1 Route Neuve, 71710 MONTCENIS - FRANCE | Email info@premiumfactory.eu | www.premiumfactory.eu
Société Anonyme Simplifié au capital de 1 000 € | Siret 840 703 797 00018 | VAT Nr: FR47840703797



TECHNICAL DATASHEET

UE Head Fragrance 350 Quattro

Item Code : PFPFFR001117

The UE Head Fragrance incorporates a high performance and precise technology in terms of fragrance diffusion. Thanks to its power, the Fragrance head allows you to change perfume in a few seconds and distribute them in all types of volumes. Using 100% natural essential oils, you will create a fourth dimension and use a rarely used Sense: smell. Available in mono, duo and quattro for more choice and power.

NOMENCLATURE :

- 1 x UE Head Fragrance 350 Quattro



TECHNICAL SPECIFICATIONS :

Size : 45 x 47 x 36 cm

Weight : 10.7 Kg

Electrical Specifications :
230V – 50Hz – 44W – 0.2A

Equipped with 4 diffusers of 20ml.

FEATURES :

Equipped with a door for easy access to the diffuser for filling and cleaning.
Designed for horizontal use only.
Integrated electronic control with TIMER and DMX.
Independent control of each scent.

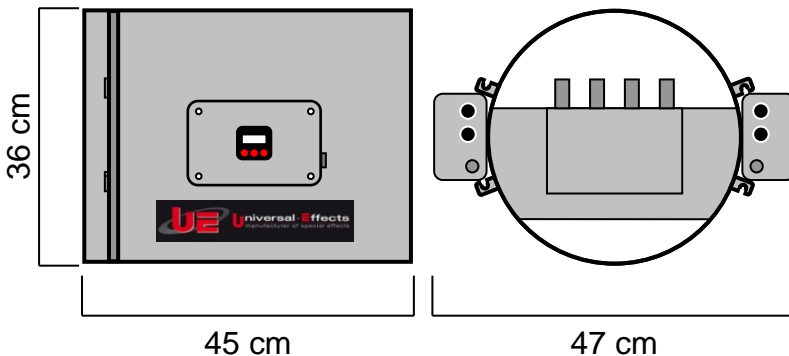

OPTIONAL ACCESSORIES:

- Large capacity diffuser 50 ml

CONSUMPTION :

The consumption varies according to the essential oil used, on average: 1 ml / h per diffuser.

CONSUMABLES :

Perfume compositions specially formulated and adapted by Universal-Effects for its machines.

Made of ALUMINUM and INOX, the UE Head Fragrance 350 Quattro is built to last. Each element has been chosen for its quality and efficiency.

Universal Effects, La qualité et l'innovation Fabriqué en France

Universal Effects est une Marque fabriquée et distribuée par la société Premium Factory SAS
1 Route Neuve, 71710 MONTCENIS - FRANCE | Email info@premiumfactory.eu | www.premiumfactory.eu
Société Anonyme Simplifiée au capital de 1 000 € | Siret 840 703 797 00018 | VAT Nr: FR47840703797