



TECHNICAL DATASHEET

UE ST- Base 350 DMX

Item Code : PFPFBA001112

The UE ST-Base 350 is very powerful and equipped with our traditional professional base that allow using on the ground, elevated foot, shoot tower or hang under a structure. It is also suitable for service companies and for fixed installations designed to operate inside and outside. The speed variation is electronically manageable locally or DMX. The base is equipped with professional connectors and a resettable fuse.

NOMENCLATURE :

- 1 x UE ST- Base 350 DMX
- 5 x Tightening buttons for heads
- 1 x PowerCon cable 5m



TECHNICAL SPECIFICATIONS :

Size: 40 x 63 x 57 cm

Weight : 20.2 Kg

Electric Characteristics :
230V – 50/60Hz – 550W – 3.8A – IP 55

Comply with norm CE ERP 2015

CHARACTERISTICS :

Sound 84 dB / 3m inside
Sound 74 dB / 3m outside.
Standard base ground.
Adjustment 110° vertical.
Can be hung under structure.
Electronic speed variation integrated in the base.
Include an electronic control with timer and DMX.

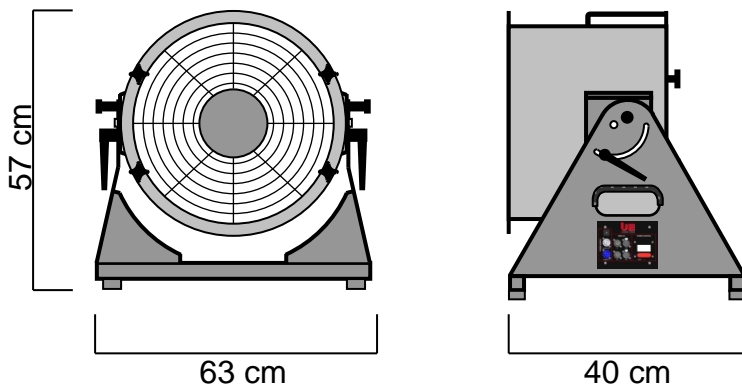

HEADS USABLE :

- | | |
|-----------------------|-------------------------|
| UE Head Foam 350 | UE Head Jet-Foam 350 |
| UE Head Snow 350 | UE Head Mist&Rain 350 |
| UE Head Twin 350 | UE Head Wind 350 |
| UE Head Fragances 350 | UE Head Jet-Bubbles 350 |
| UE Head AirFlame 350 | UE Head Projection 350 |

OPTIONAL ACCESSORIES:

- UE Skate Board 350
- UE Feet 50, 70, 100 (x 4)
- UE Shoot Tower 350

Manufactured in ALUMINIUM and STAINLESS, UE ST- Base 350 DMX is done for last. Each element was chosen for his quality and efficiency.

Universal Effects, La qualité et l'innovation Fabriqué en France

Universal Effects est une Marque fabriquée et distribuée par la société Premium Factory SAS
1 Route Neuve, 71710 MONTCENIS - FRANCE | Email info@premiumfactory.eu | www.premiumfactory.eu
Société Anonyme Simplifié au capital de 1 000 € | Siret 840 703 797 00018 | VAT Nr: FR47840703797



TECHNICAL DATASHEET

UE Head Mist & Rain 350

Item Code : PFPFRA001114

The UE Head Mist and Rain allows you to create your own weather. To refresh the mood, project water in mist mode. When you need to create a well-watered scene with wind, switch to rain mode. Effect used in cinema, video production and theme park. Delivered complete with its pump on support and all necessary hoses.

NOMENCLATURE :

- 1 x UE Head Mist & Rain 350
- 1 x Pump 350
- 1 x Hose Kit

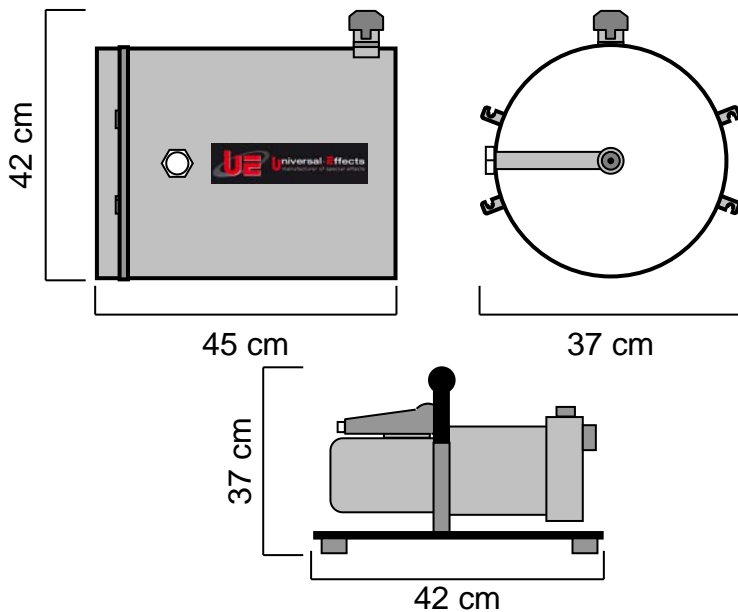

TECHNICAL SPECIFICATIONS :

Size : 45 x 37 x 42 cm
Weight : 24.6 Kg

NECESSARY ACCESSORIES:

Pump 350: Size : 42 x 23 x 37 cm
 Weight : 14,6 Kg
 Electrical Specifications:
 230V – 50Hz – 800W – 3,7A

Hose Kit : Length : 5 m and 7 m
 Weight : 5,6 kg

BASES USABLE :

- UE ST-Base 350
- UE XT- Base 350

CONSUMPTION :

- On UE ST / XT- Base 350 projection of mist cloud at 6m.
- Water consumption with the mist nozzle: 3L / mn
- On EU ST / XT- Base 350 rain projection at 6m.
- Water consumption with the rain nozzle: 47L / mn

CONSUMABLE :

water (provide storage barrel).

Universal Effects, La qualité et l'innovation Fabriqué en France