



# TECHNICAL DATASHEET

## UE Base Tube DMX

Item Code : PFPTBA007111

The UE Base Tube DMX is compact, highly efficient and ultra quiet thanks to its high-tech centrifugal fan. It is completely adapted to the uses in Theater, Opera and TV. Local and DMX electronic control of the speed variation and the effects trigger for the DMX version. Equipped with a professional connection and a resettable fuse.

### NOMENCLATURE :

- 1 x UE Base Tube DMX
- 1 x Power Cable 2m PowerCon



Back view

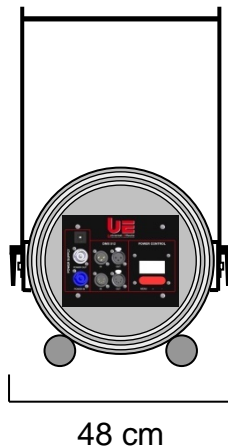
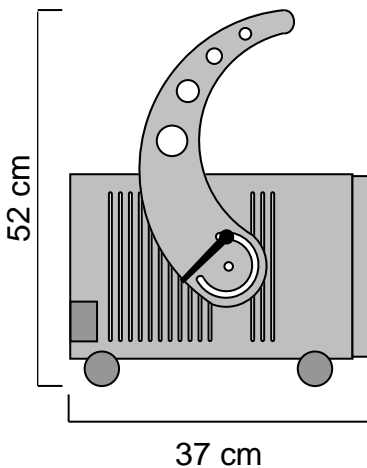

### TECHNICAL SPECIFICATIONS :

Size : 37 x 48 x 52 cm

Weight : 9.2 Kg

Electrical Specifications :  
230V – 50/60Hz – 230W – 1.7A – IP 54

Connexion IN/OUT en fiche PowerCon

### FEATURES :

- Noise 65 dB / 3m indoors.
- Noise 60 dB / 3m outdoors.
- Lyre hanging.
- Possibility of posing on the ground and parrot.
- Electronic variation of speed.
- Integrated electronic control with timer and DMX.
- Wind speed 83km / h.

### USABLE HEADS :

- UE Head Foam Tube
- UE Head Snow Tube
- UE Head Bubble Tube
- UE Head Fragrance Tube
- UE Head Projection Tube
- UE Head Wind Tube
- UE Head Striptease Tube
- UE Head AirFlame Tube
- Light

### OPTIONAL ACCESSORY :

- UE Ground Foot Tube

Made of ALUMINUM and INOX, the UE Base Tube DMX is built to last. Each element has been chosen for its quality and efficiency.

**Universal Effects, La qualité et l'innovation Fabriqué en France**

Universal Effects est une Marque fabriquée et distribuée par la société Premium Factory SAS  
1 Route Neuve, 71710 MONTCENIS - FRANCE | Email info@premiumfactory.eu | www.premiumfactory.eu  
Société Anonyme Simplifiée au capital de 1 000 € | Siret 840 703 797 00018 | VAT Nr: FR47840703797



# TECHNICAL DATASHEET

## UE Head Fragrance Tube Duo

Item Code : PFPTFR007016

The UE Head Fragrance Tube Duo allows you to spread a fragrance in seconds and create your own olfactory ambiances. Compact, it is suitable for medium-sized volumes. It incorporates a very powerful and precise technology in terms of perfume diffusion. Without deposit and without public aggression. Using elaborate scented compositions, she creates a fourth dimension. You will thus use a rarely used Sense: smell.

### NOMENCLATURE :

- 1 x UE Head Fragrance Tube Duo  
With connexion harting



### TECHNICAL SPECIFICATIONS :

Size : 35 x 28 x 33 cm

Weight : 4.8 Kg

Electrical Specifications :  
230V – 50/60Hz – 22W – 0.10A – IP 44

Equipped with 2 diffusers of 20ml.

### FEATURES :

Equipped with a door for easy access to diffusers for filling and cleaning.  
Designed for horizontal use only.  
Integrated electronic control with TIMER and DMX.  
Independent control of each scent.  
The consumption varies according to the composition used, on average: 1 ml / h per diffuser.

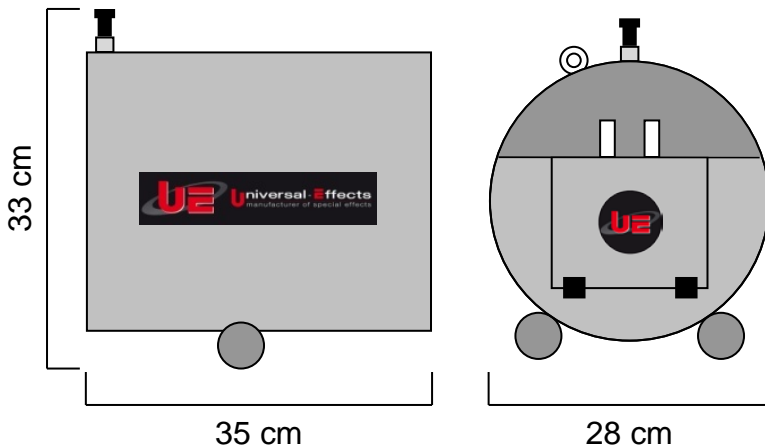

### CONSUMABLES :

Perfume compositions specially formulated and adapted by Universal-Effects for its machines.

### OPTIONAL ACCESSORIES :

- UE Box Switch or Dimmer

Made of ALUMINUM and INOX, the UE Head Fragrance Tube DUO is built to last. Each element has been chosen for its quality and efficiency.

**Universal Effects, La qualité et l'innovation Fabriqué en France**

Universal Effects est une Marque fabriquée et distribuée par la société Premium Factory SAS  
1 Route Neuve, 71710 MONTCENIS - FRANCE | Email [info@premiumfactory.eu](mailto:info@premiumfactory.eu) | [www.premiumfactory.eu](http://www.premiumfactory.eu)  
Société Anonyme Simplifié au capital de 1 000 € | Siret 840 703 797 00018 | VAT Nr: FR47840703797